



### **CRONO CLK306** side opening aluminium housing with fiber optic media converter

- ✓ side opening housing
- ✓ weatherproof rating IP66/67
- ✓ fiber optic media converter
- ✓ transmission Ethernet (10Base-T) Ethernet (100Base-TX)
- ✓ half or full duplex auto-negotiation
- ✓ power supply 12Vdc 1A for camera
- ✓ easy fastening and positioning
- ✓ wide range of accessories

OPTICAL FIBER  
READY



#### **Side opening housing with fiber optic media converter integrated**

The **CRONO CLK306 housing** has been developed in order to ensure a simple mounting and maintenance of all the most common cameras, also of medium-large size, IP and megapixels, with various lenses. The housing features an integrated fiber optic media converter, that supports **half/full duplex** auto-negotiation: it is compatible with SFP modules (max. distance of 110Km) and a 12Vdc 1A camera power supply is pre assembled.

The die-cast aluminum construction provides high impact resistance and good heat dissipation to the outside while the side opening facilitates accessibility to the camera and connectivity during installation and maintenance.

Available there are a wide range of accessories: double heating, anticondensing glass, antibreaking glass, alarm-tamper system, internal ventilation, safety-lock system.

Suitable for every installations of cameras, megapixel cameras with various lenses.

# - DATA SHEET -

## camera housing

### useful area

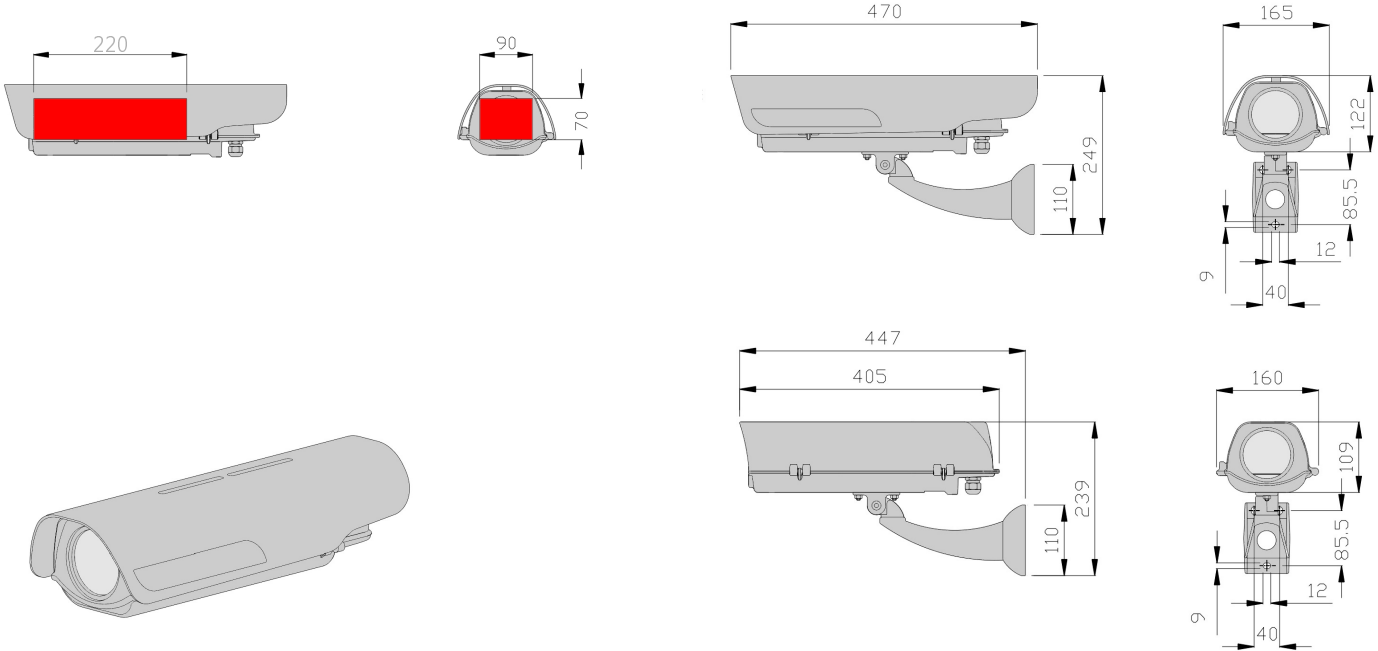

the values are in millimeters

### TECHNICAL DATA

#### GENERAL

- body made in aluminium
- sunshield in technopolymer UV with wide range of adjustment
- painted with polyester powder RAL 7035 (light grey)
- stainless steel bolts and screws
- side opening housing
- power supply 230-12Vdc 1,3A for camera
- cable glands: 2x PG9 and 1x rotating fitting for corrugated sheath Ø16mm
- heater
- wide range of accessories
- supplied with instruction manual
- according to RoHS compliance

#### ELECTRICAL

- heater: 230V, 110V, 24V, 12V  
consumption max. 30W  
t on 15°C t off 22°C +/- 3°C
- ventilation: 230V, 110V, 24V, 12V  
consumption max. 2W
- type of signal: 10Base-T (Ethernet) or 100Base-TX (fast Ethernet)  
rate: 10/100 Mbits/s (autonegotiation)  
operation mode: full duplex – half duplex (autonegotiation)  
UTP max. length: 100m.  
Electrical connector: RJ45
- compatible SFP module (distance up to 110Km.)
- green led: media converter ON
- amber led: activity
- red led: RX error optical receiver
- red led: TX error optical emitter

#### MECHANICAL

- usable internal space 90x70mm (WxH)
- useful lenght: 220mm
- glass window Ø 75mm.
- weatherproof rating IP66/67
- indoor/outdoor installations
- operating temperature with heater from -20°C to +60°C
- weight 2,9 Kg. (KIT version)

#### ACCESSORIES

- VA306** antibreaking glass
- VC306** anticondensing glass
- RP306** double heater
- VI306** internal ventilation
- TP306** alarm-tamper system
- LC306** safety-lock system
- SFPM01** module SFP (couple fiber) **multi mode** max distance 2Km.
- SFPM02** module SFP (couple fiber) **single mode** max distance 20Km.
- SFPM03** module SFP (single fiber) **single mode** max distance 10Km.
- SFPM04** module SFP (single fiber) **single mode** max distance 10Km.

#### RELATED PRODUCTS

- STS500** ceiling bracket
- SP/A** pole adaptor
- SA/A** corner adaptor
- PA1** reinforcing support plate
- PA1/SD** reinforcing support plate in weatherproof box

code	unit weight (Kg.)	package dimensions (cm.) WxHxL	package weight (Kg.)
KIT CLK306	2,9	21,0 x 18,8 x 50,0	3,20

Specifications are subject to change without notice, weights and dimensions are indicative.

rev.2415