

# DATASHEET

## CSX800

### AISI 316L stainless steel housing

- AISI 316L stainless steel housing
- weatherproof rating IP67
- slide opening system
- joint with 3rd axis for easier orientation
- integrated wiper (on request)
- easy fastening and positioning
- wide range of accessories



IP 67  
STANDARD 

#### AISI316L stainless steel housing

The **CSX800** is a cylindrical weatherproof housing, entirely made of AISI 316L stainless steel. The electropolishing treatment increases the corrosion resistance and makes the housing particularly indicated for installations in marine, industrial and chemical environments.

It is supplied with a special joint, realized by Global Proof with an exclusive system that allows the third axis tilt: in this way it is possible to mount the housing also in an arched ceiling or on a wall that is not perpendicular to the ground.

The lightweight of this housing allows to mount it also in small pan-tilt systems.

Suitable for all the most common IP cameras, megapixel cameras, with various lenses.

# DATASHEET

## TECHNICAL DRAWINGS

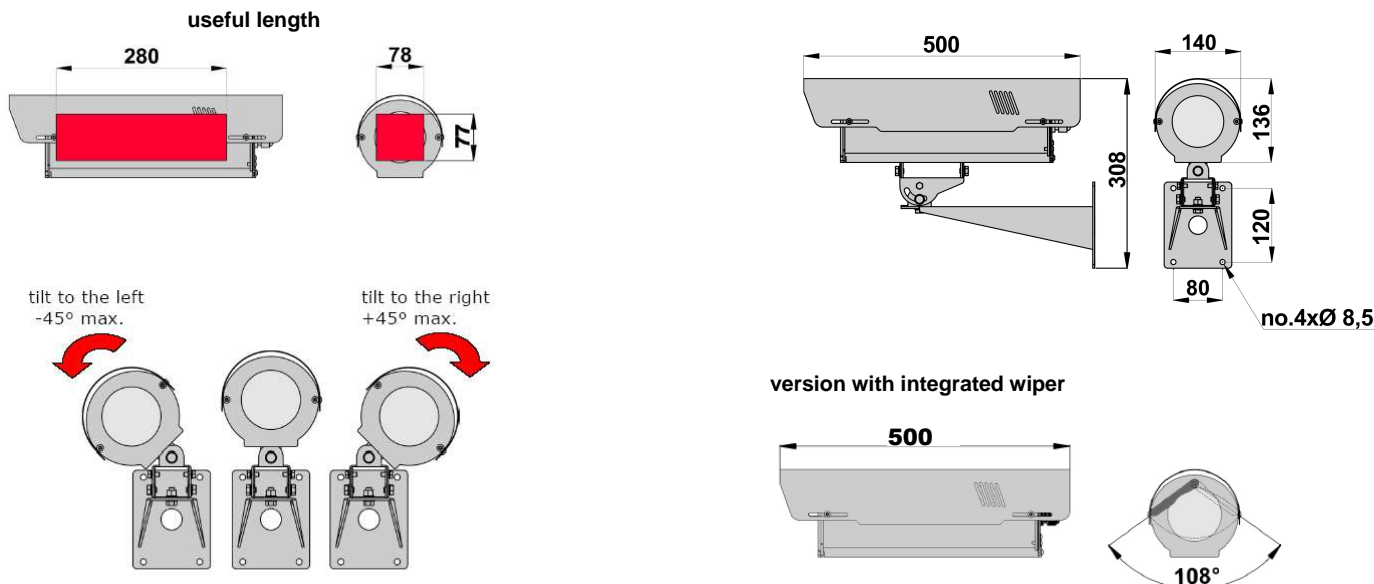

the values are in millimeters

## TECHNICAL DATA

### GENERAL

- body made in stainless steel AISI 316L
- sunshield in stainless steel AISI 316L with wide range of adjustment
- stainless steel A4 bolts and screws
- wall bracket made in stainless steel AISI 316L
- extractable slide-out body
- no. 2 metallic cable glands PG13,5
- heater
- wide range of accessories
- supplied with instruction manual
- according to RoHS compliance

### ELECTRICAL

- thermostatically controlled heater  
available voltages: 230V, 110V, 24V, 12V  
max. power: 30W  
t on: +15°C, t off: +22°C (+/- 3°C)
- thermostatically controlled blower  
available voltages: 230V, 110V, 24V, 12V  
max. power: 2W  
t on 37°C t off 27°C +/- 3°C
- integrated wiper:  
IN 230Vac 5W  
IN 24Vac 5W

### MECHANICAL

- usable internal space 78x77mm.(BxH) or Ø 95
- useful length: 220mm
- glass window Ø 75mm.
- weatherproof rating IP67
- indoor/outdoor installations
- operating temperature with heater from -20°C to +60°C (with double heater from -40°C to +60°C)
- weight 7 Kg. (weight of the housing in KIT version)

### ACCESSORIES

- VI800** internal ventilation pre-assembled
- RD800** double heater for low temperature (down to -40°C)
- AL800/A** power supply 230/12Vdc 1,3A
- AL800/B** power supply 230/24Vac 500mA
- SNF800** adaptor plate for pan/tilt devices
- WTP5** water tank 5l. and pump with delivery up to 5m, 11m or 19m (three versions available)
- WTP25** water tank 25l. and pump with delivery up to 5m, 11m or 19m (three versions available)

### RELATED PRODUCTS

- SP/C** pole adaptor AISI 316L
- SA/C** corner adaptor AISI 316L
- STS800** adaptor plate for ceiling mounting

code	unit weight (Kg.)	package dimensions (cm.) WxHxL	package weight (Kg.)
CSX806 + ST800	7,0 tot.	19,0 x 15,0 x 46,0 + 19,0 x 15,0 x 46,0	7,40 (tot.)