

MAXIMUS MMX

EX-PROOF FULL HD CAMERA IN A COMPACT DESIGN



IP66/IP67
IP68/IP69

TYPE 4X
TYPE 6P



- Certifications for use in Zones 1 and 2, IIB T6 or T5 Group (Gas) and in Zones 21 and 22, IIIC T85°C or T100°C Group (Dust)
- AISI 316L stainless steel construction
- Supports for ceiling, wall and parapet installation supplied
- Camera Full HD 1080p, 3x or 10x with image stabilizer



MAXIMUM RESISTANCE IN THE MOST CRITICAL ENVIRONMENTS

The explosion-proof Full HD camera MAXIMUS MMX is perfect for efficient video surveillance and control of processes in hazardous environments where the atmosphere is potentially explosive due to the presence of inflammable gases or dust, typical of the Oil&Gas, marine or industrial and foodstuff sectors.

The housing is entirely manufactured in stainless steel AISI 316L offering complete resistance to corrosion. Thanks to its compactness (only 116mm) and contained weight (only 6.5 kg (14.3lb)), it can be installed in narrow locations typical of industrial or naval surroundings.

The IP66/IP67/IP68/IP69 level guarantees complete protection against bad weather and water immersion.

Another important feature of the camera is the extended certification temperature range of -40°C to 70°C.

The MAXIMUS MMX product with 10x Full HD camera is Lloyd's Register Type Approval System Test Specification Number 1 certified and therefore can be used in Marine and Offshore applications for environmental categories ENV1, ENV2, ENV3 and ENV5 (eg. passenger ships, open-air decks, closed spaces and technical areas that may be subject to heat generated by other equipment, potentially explosive areas, docking procedures).

HIGH QUALITY IMAGE

The Full HD, 1080p camera, with 3x or 10x motorised zoom lens, offers multiple video streams (H.264/AVC, MJPEG, JPEG, MPEG4) and provides exceptional image quality, picking out every detail in a scene, even in the harshest environmental conditions. The 10x camera is also equipped with a digital image stabilizer.

100% MADE IN VIDEOTECH

Videotec guarantees the extreme robustness and reliability of all its "all-in-one products" with hundreds of validation tests. Mechanics, electronics, positioning, networking, software and firmware are developed end-to-end by the internal Videotec team, with total know-how of all the network products offered.

At the heart of Videotec's product development is the concept of cyber-sustainability. To help customers protect their video surveillance systems and keep them secure, Videotec provides constant updates, training and support throughout the lifecycle of its products, regardless of how old the device is or whether it is still for sale.

Thanks to digitally signed firmware, password-restricted access, access control, centralised management of certificates and compliance with ONVIF Security Service specifications, Videotec guarantees that all its IP products will have the highest level of security during data transfer and device access.

MAXIMUS MMX therefore offers the Videotec warranty of being a reliable platform, that is cyber-safe, future-proof and easily integrated with third party products.

TECHNICAL DATA

MECHANICAL

AISI 316L stainless steel construction

External shot peened and electro-polished surfaces

Sunshield

Supports for wall, ceiling or parapet installation

Unit weight:

- 6.5kg (14.3lb) (housing only + mounting bracket)
- 8.5kg (18.7lb) (housing with 4m (13ft) armoured multipolar cable)

CABLE GLANDS

Cable entry: 1 hole, 1/2" NPT

Cable gland Ex d 1/2"NPT (with pre-installed cable only)

HOUSING'S WINDOW

Material: Thermally tempered glass

Usable diameter: 73.5mm (2.9in)

ELECTRICAL

Supply voltage/Current consumption

- 24Vac, 1.32A, 50/60Hz
- 24Vdc, 0.9A
- PoE+ (IEEE 802.3at)

Power consumption:

- 21W (24Vac, 1.32A, 50/60Hz)
- 20W (24Vdc, 0.9A)
- 21W (PoE+)

Armoured cable

- External diameter: 18.6mm (0.73in)±0.2mm (0.008in)
- Diameter under armature: 13.8mm (0.54in)
- Colour: black RAL 9005

Armoured cable composition:

- 3x1mm² (17AWG)
- 4x2x0.22mm² (24AWG) (cat. 5E F/STP)

NETWORK

Ethernet connection: 100 Base-TX

Connector: RJ45

CYBERSECURITY

Digitally signed firmware

Password restricted access (HTTP digest)

Support of various user access levels

Control of accesses IEEE 802.1X

HTTPS cryptography using TLS1.0, TLS1.1, TLS1.2 and TLS1.3

Centralised certificate management

Complies with ONVIF Security Service specifications

VIDEO

Video encoder

- Communication protocol: ONVIF, Profile Q, Profile S and Profile T
- Device configuration: TCP/IPv4-IPv6, UDP/IPv4-IPv6, HTTP, HTTPS, NTP, DHCP, WS-DISCOVERY, DSCP, IGMP (Multicast), SOAP, DNS
- Streaming: RTSP, RTCP, RTP/IPv4-IPv6, HTTP, Multicast
- Video compression: H.264/AVC, MJPEG, MPEG4, snapshot JPEG
- 3 independent video streams Full HD
- Image resolution: from 320x180pixel up to 1920x1080pixel in 8 steps
- Selectable frame rate from 1 to 60 images per second (fps)
- Web Server
- Motion Detection
- QoS: Differentiated DSCPs for streaming and device management
- SNMP and NTCIP protocols

CAMERAS

Day/Night Full HD 3x

Resolution: Full HD 1080p (1920x1080pixel)

Signal system: max 1080p/30fps

Image Sensor: 1/2.8 type Exmor™ CMOS sensor

Effective pixels: 3.27Megapixel

Minimum Illumination, colour (ICR-OFF):

- 1lx, 1/30s, F1.2, 50% (Normal mode)
- 0.25lx, 1/30s, F1.2, 50% (High sensitivity mode)

Minimum Illumination, B/W (ICR-ON):

- 0.1lx, 1/30s, F1.2, 50% (Normal mode)
- 0.03lx, 1/30s, F1.2, 50% (High sensitivity mode)

Lens:

- From f= 3.0mm (wide) up to 9.0mm (tele)
- From F1.2 up to F2.1

Zoom: 3x (36x with digital zoom)

Horizontal Viewing Angle: From 90° (wide) up to 32° (tele)

Minimum object distance: 300mm (11.8in) (wide to tele)

Shutter speed: From 1/1s up to 1/10000s, 22 steps

White balance: Auto, ATW, Indoor, Outdoor, Outdoor Auto, Sodium vapor lamp (Fix, Auto), Manual

Wide Dynamic Range: On/Off

Exposure Control: Auto, Manual, Priority (Shutter priority, Iris priority), Brightness

S/N Ratio: 50dB

Gain limit: up to 28dB

Backlight Compensation

Day/Night Full HD 10x

Resolution: Full HD 1080p (1920x1080pixel)

Signal system: 1080p/60fps max

Image Sensor: 1/3" CMOS sensor

Effective pixels: 2.48Megapixel

Minimum Illumination, colour (ICR-OFF):

- 0.5lx IRE 50%
- 0.125lx IRE 50% (Slow Shutter)

Minimum Illumination, B/W (ICR-ON):

- 0.1lx IRE 50%
- 0.025lx IRE 50% (Slow Shutter)

Lens:

- From f= 5.1mm (wide) up to 51mm (tele)
- From F1.6 up to F1.8

Zoom: 10x (320x, with digital zoom)

Horizontal Viewing Angle: from 54° (wide) up to 4.9° (tele)

Minimum object distance: from 100mm (3.9in) (wide) up to 1000mm (39.4in) (tele)

Shutter speed: from 1/8s up to 1/30000s, 14 steps

White balance: Auto, Indoor, Outdoor, Manual

Wide Dynamic Range: On/Off, Light level

Exposure Control: Auto, Manual, Shutter priority, Iris priority, Brightness

S/N Ratio: 50dB

De-fog: Off, Auto, Manual

Backlight Compensation

Digital image stabilization: On/Off

ENVIRONMENT

For indoors and outdoors installation

Operating temperature: from -40°C (-40°F) up to +65°C (149°F)

Certification temperature: from -40°C (-40°F) up to +65°C (149°F) (T6/T85°C) or +70°C (158°F) (T5/T100°C)

Relative humidity: from 10% up to 95% (no condensation)

CERTIFICATIONS

Electrical safety (CE): EN60950-1, IEC60950-1, EN62368-1, IEC62368-1

Electromagnetic compatibility (CE): EN61000-6-4, EN61000-3-2, EN61000-3-3, EN50130-4, EN55032 (Class A)

RoHS (CE): EN50581

Outdoor installation (CE): EN60950-22, ICE60950-22

IP protection degree (EN/IEC60529): IP66, IP67, IP68 (2 hours, 5m (16ft)), IP69

Vibration test: EN50130-5, EN60068-2-6

UL certification (UL60950-1, CAN/CSA C22.2 No. 60950-1-07, UL62368-1 CAN/CSA C22.2 No. 62368-1-14): cULus Listed

Electromagnetic compatibility (North America): FCC part 15 (Class A), ICES-003 (Class A)

Level of protection Type (UL50E): 4X, 6P

BIS certification: IS 13252(PART 1):2010/IEC 60950-1 : 2005 (certification only valid for the code: MMX2D0ZA)

RCM (Australian and New Zealand Regulatory Compliance Mark)

NDAA-compliant

CERTIFICATIONS - EXPLOSION-PROOF APPLICATIONS

ATEX (EN 60079-0, EN 60079-1, EN 60079-31)

IECEx (IEC 60079-0, IEC 60079-1, IEC 60079-31)

EAC EX (TR CU 012/2011)

INMETRO (ABNT NBR IEC 60079-0, ABNT NBR IEC 60079-1, ABNT NBR IEC 60079-31)

KCs (Employment and labor department. 2020-33), only versions without armoured cable

UL listed for USA (UL 60079-0, UL 60079-1, UL 60079-31)

UL listed for Canada (CAN/CSA-C22.2 NO. 60079-0, CAN/CSA-C22.2 NO. 60079-1, CAN/CSA-C22.2 NO. 60079-31)

For further details on certifications and markings, consult the relevant table.

CERTIFICATIONS - MARINE APPLICATIONS

Lloyd's Register Marine Type Approval certification (only for models with Day/Night camera 10X zoom, FullHD):

- Test Specification Number 1 (ENV1, ENV2, ENV3, ENV5)

Electromagnetic compatibility: EN60945

Salty fog resistance: EN60068-2-52

Tested at 70°C (158°F) for 16 hours in compliance with EN60068-2-2

ACCESSORIES

MBX1MAA	Explosion-proof communication box in stainless steel, IN 230Vac, with EMC filter for marine certification
MBX2MAA	Explosion-proof communication box in stainless steel, IN 24Vac, with EMC filter for marine certification
MBX3MAA	Explosion-proof communication box in stainless steel, IN 120Vac, with EMC filter for marine certification
MBA15SA	Explosion-proof communication box in aluminium, IN 230Vac
MBA25SA	Explosion-proof communication box in aluminium, IN 24Vac
MBA35SA	Explosion-proof communication box in aluminium, IN 120Vac
OCTEXB1/2P	Barrier cable gland in nickel-plated brass EX 1/2" NPT, unarmoured cable IECEx-ATEX-EAC Ex
OCTEXBA1/2P	Barrier cable gland in nickel-plated brass EX 1/2" NPT, armoured cable IECEx-ATEX-EAC Ex
OCTEX1/2C	Cable gland in nickel-plated brass EX 1/2" NPT, unarmoured cable IECEx-ATEX-EAC Ex
OCTEXA1/2C	Cable gland in nickel-plated brass EX 1/2" NPT armoured cable IECEx-ATEX-EAC Ex
OCTEXS1/2C	Cable gland in nickel-plated brass EX 1/2" NPT, unarmoured cable IECEx-ATEX-EAC Ex

For further details about cable glands part numbers, please refer to the relevant table.

BRACKETS AND ADAPTORS

MMXCWCOL Pole and corner adaptor module in stainless steel AISI 316L

PACKAGE

Model Number	Weight	Dimensions (WxHxL)	Master carton
MMX2D0ZA	8kg (18lb)	32.5x19x23cm (12.8x7.5x9in)	2
MMX2DAZA	11kg (24.2lb)	64x20.8x59cm (25.2x8.2x23.2in)	-
MMX2DBZA	14kg (31lb)	64x20.8x59cm (25.2x8.2x23.2in)	-

CABLE GLANDS AND ACCESSORIES 1/2" NPT

Type	Certification	Operating temperature	Cable	Model Number	Diameter of the external cable	Under armor cable diameter
Barrier cable gland	IECEX/ATEX/EAC Ex	-60°C (-76°F) / +135°C (+275°F)	Armoured cable	OCTEXBA1/2P	15.5 - 21.1mm (0.61-0.83in)	14mm (0.6in) max
Cable gland with gasket	IECEX/ATEX/EAC Ex	-60°C (-76°F) / +100°C (+212°F)	Unarmoured cable	OCTEX1/2C	3.2 - 8.0mm (0.12-0.31in)	–
			Unarmoured cable	OCTEXS1/2C	6.5 - 11.9mm (0.26 - 0.47in)	–
			Armoured cable	OCTEXA1/2C	12.5 - 20.5mm (0.49 - 0.8in)	10 - 14.3mm (0.4 - 0.56in)
Plug EX 1/2"NPT	IECEX/ATEX/EAC Ex	-100°C (-148°F) / +400°C (+752°F)	–	OEXPLUG1/2P	–	–

MAXIMUS MMX - CERTIFICATIONS AND MARKINGS (WITH CABLE)

Certification	Marking	Ambient temperature
ATEX	Ⓜ II 2 G Ex db IIB T6...T5 Gb Ⓜ II 2 D Ex tb IIIC T85°C...T100°C Db	-40°C ≤ Ta ≤ +65°C or +70°C
IECEX	Ex db IIB T6...T5 Gb Ex tb IIIC T85°C...T100°C Db	
EAC Ex	1Ex d IIB T6...T5 Gb X Ex tb IIIC T85°C...T100°C Db X	
INMETRO	Ex db IIB T6...T5 Gb Ex tb IIIC T85 °C...T100 °C Db	

MAXIMUS MMX - CERTIFICATIONS AND MARKINGS (WITHOUT CABLE)

Certification	Marking	Ambient temperature
ATEX	Ⓜ II 2 G Ex db IIB T6...T5 Gb Ⓜ II 2 D Ex tb IIIC T85°C...T100°C Db	-40°C ≤ Ta ≤ +65°C or +70°C
IECEX	Ex db IIB T6...T5 Gb Ex tb IIIC T85°C...T100°C Db	
EAC Ex	1Ex d IIB T6...T5 Gb X Ex tb IIIC T85°C...T100°C Db X	
KCs	Ex d IIB T6...T5 Ex tb IIIC T85°C...T100°C	
INMETRO	Ex db IIB T6...T5 Gb Ex tb IIIC T85 °C...T100 °C Db	
Hazardous Location America	Class I, Zone 1, AEx db IIB T6...T5 Zone 21, AEx tb IIIC T85°C...T100°C Class I, Div 2, Group C, D Class II, Div 2, Group F and G	
Hazardous Location Canada	Ex db IIB T6...T5 Gb Ex tb IIIC T85°C...T100°C Db Class I, Div 2, Group C, D Class II, Div 2, Group F and G	

MAXIMUS MMX - CONFIGURATION OPTIONS

	Voltage	Camera	Connections	Video Output	
MMX	2 24Vdc/ 24Vac, PoE+	C Day/Night camera 3X zoom, FullHD	0 Without cable, without cable gland	Z IP H.264/AVC control, ONVIF protocol Profile Q, Profile S and Profile T	A
		D Day/Night camera 10X zoom, FullHD	A Cable gland Ex d 1/2" NPT and 4m (13ft) armoured cable		
			B Cable gland Ex d 1/2" NPT and 10m (32.8ft) armoured cable		

TECHNICAL DRAWINGS

The indicated measurements are expressed in millimetres.

WALL MOUNTING

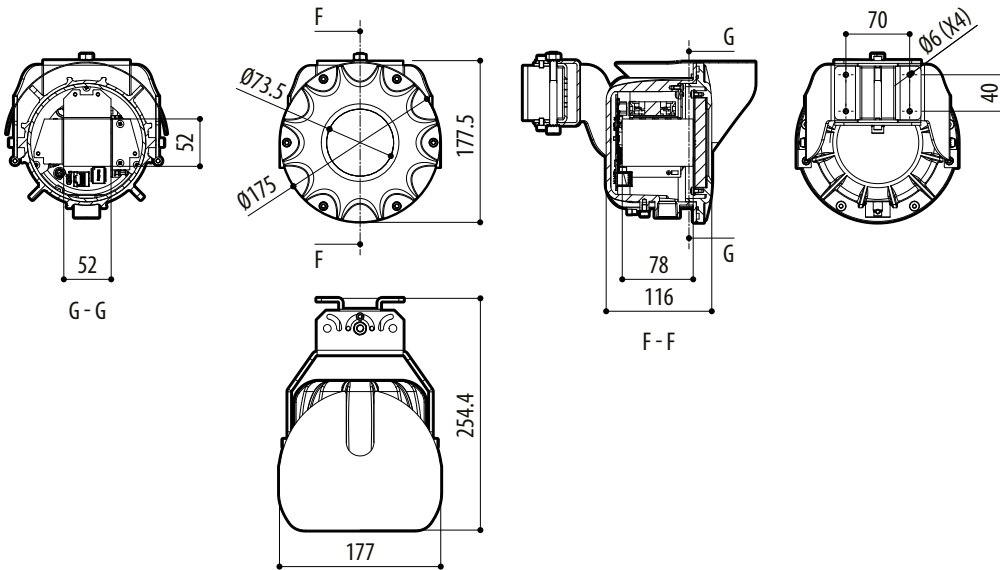

PARAPET OR CEILING MOUNTING

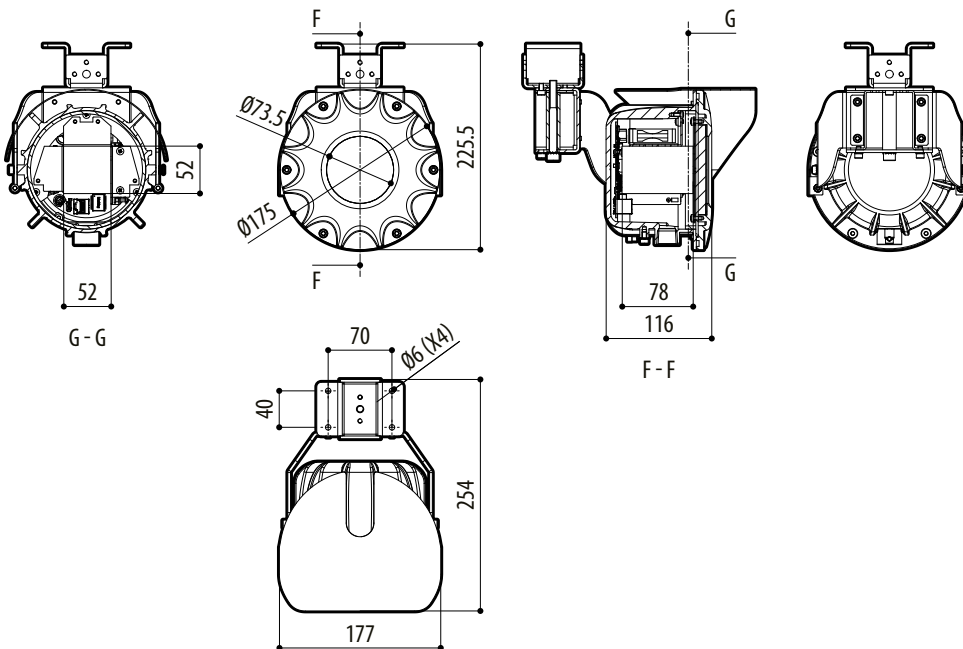

MAXIMUS MMX