

NDA-U-WMP Wall mount plate

www.boschsecurity.com



BOSCH
Invented for life



- ▶ Modular design for easy and fast installation of Bosch dome cameras (fixed and PTZ)
- ▶ Perfectly matched parts for easy selection and in-field installation
- ▶ Weather resistant finish to maintain the cosmetic appearance over the years

Bosch's **Modular Camera Mounts & Accessories** offer a modular range of camera mounts, mounting adapters, camera interface plates and surveillance cabinets. All items are easy to handle and simplify the installations of our cameras across a wide range of applications to suit all of your needs. The mechanical design is extremely robust and suitable for any environment, both indoor and outdoor. The accessories are designed with usability in mind. It's modern and sleek design is a perfect combination of form and function.

Functions

Wall mount plate

The wall mount comes with an installation plate with cable feedthrough, for easy installation of external cables. The installation plate has mounting holes large enough for robust screws. During the mounting of the arm to the installation plate you have some clearance to level the arm after fixing it to the installation plate.

Universal accessory combinations

On this accessory you can mount:

- NDA-U-WMT Pendant wall mount
- NDA-U-PMT Pendant ceiling mount

Certifications and approvals

Environmental

Salt mist	IEC60068-2-52
Impact	IK10
Ingress Protection	IP66

Parts included

Quantity	Component
1	Wall mount plate
1	Quick Installation Guide

Technical specifications

Mechanical

Dimensions (W x H x D)	170 x 216 x 47 mm (6.7 x 8.5 x 1.9 in)
Weight	1425 g (3.14 lb)
Standard Color	White (RAL 9003)

Mechanical

Construction Material	Aluminum alloy
Mounting	To a wall

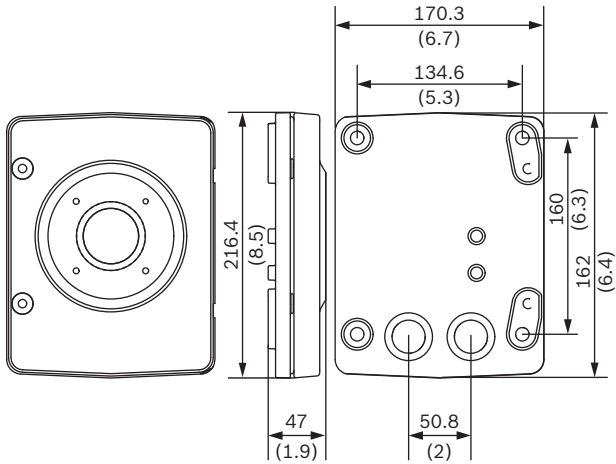

Dimensions in mm (inch)

Ordering information

NDA-U-WMP Wall mount plate

Back plate for universal wall mount, corner mount and pole mount, white, IP66

Order number **NDA-U-WMP**

Accessories

NDA-U-WMT Pendant wall mount

Universal wall mount for dome cameras, white

Order number **NDA-U-WMT**

Represented by:

Europe, Middle East, Africa:
 Bosch Security Systems B.V.
 P.O. Box 80002
 5600 JB Eindhoven, The Netherlands
 Phone: + 31 40 2577 284
 emea.securitysystems@bosch.com
 emea.boschsecurity.com

Germany:
 Bosch Sicherheitssysteme GmbH
 Robert-Bosch-Ring 5
 85630 Grasbrunn
 Germany
 www.boschsecurity.com

North America:
 Bosch Security Systems, Inc.
 130 Perinton Parkway
 Fairport, New York, 14450, USA
 Phone: +1 800 289 0096
 Fax: +1 585 223 9180
 onlinehelp@us.bosch.com
 www.boschsecurity.us

Asia-Pacific:
 Robert Bosch (SEA) Pte Ltd, Security Systems
 11 Bishan Street 21
 Singapore 573943
 Phone: +65 6571 2808
 Fax: +65 6571 2699
 apr.securitysystems@bosch.com
 www.boschsecurity.asia